

MicroStep - MIS

COMPLEX SOLUTIONS FOR THE REAL WORLD

AVIATION WEATHER



30 YEARS
OF EXPERIENCE

AUTOMATED WEATHER OBSERVATION SYSTEM

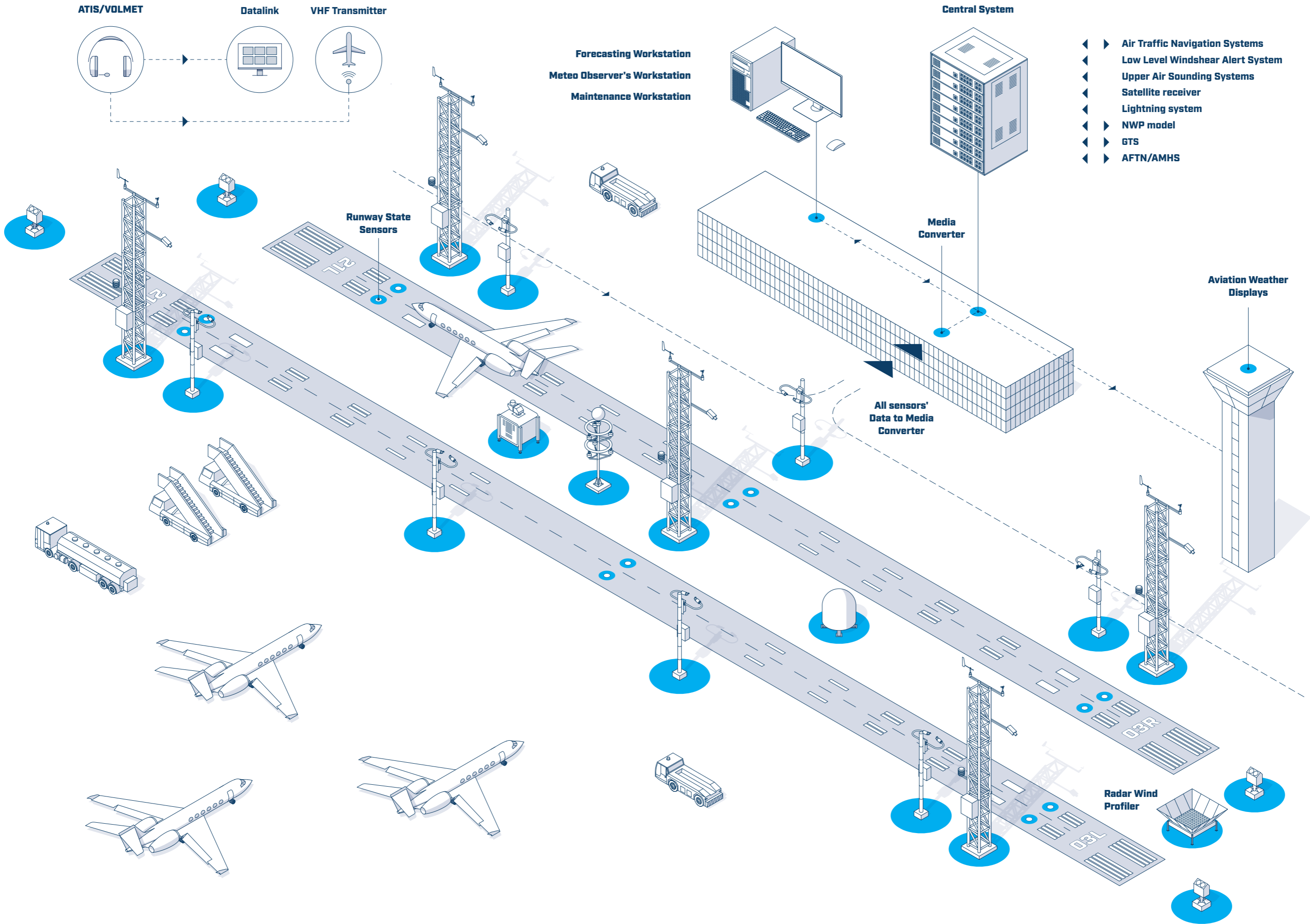

EXPERTS IN AVIATION METEOROLOGY

Aviation weather solutions constitute the majority and the most remarkable part of MicroStep-MIS product portfolio. The company has officially been certified as an air navigation service provider by Civil Aviation Authority of the Slovak Republic (accredited by the European Aviation Safety Agency).

The company's aviation systems are suitable for civil regional, national, international airports scalable up to ICAO CAT III category, as well as military airports and NATO airbases. The systems are ICAO and WMO compliant and adaptive to various climatic conditions and local practices of each region.

IMS4 integrated monitoring system is a complex multipurpose software that has been in development since 1993. The system is designed for nonstop unattended operation and it has already been installed in various countries all over the world.

High level of customization allows each of our systems to adapt to the individual requirements and needs of each client. Due to the constant development of standards and technological progress the upgrades and system actualization form an integral part of MicroStep-MIS activities.



CONTENTS

Field Measurement System	8
IMS4 Automated Weather Observation System	10
IMS4 Metreporter	14
IMS4 Helideck	15
IMS4 Low Level Wind Shear Alert System	16
Lidar for Detection of Low Level Wind Shear	18
IMS4 Airport Runway Weather Information System	20
Recent Improvements	21
Aquaplaning Assessment and Nowcasting	22
IMS4 ATIS / VOLMET	24
IMS4 Pilot Briefing	25
IMS4 Runway Visual Range System	26
Fog Monitoring And Forecasting	27
IMS4 Airport Lightning Alert System	28
Aeronautical Climatological Database	29
IMS4 Aviation Weather Decision Support System	30
SESAR From Research to Innovations	32

HIGH LEVEL OF CUSTOMIZATION

Individual approach allows us to adapt the system and its components to the individual requirements and needs of the client.

200 mil+
served passengers annually

30

supplied countries worldwide

350+

aviation systems since 1995

FIELD MEASUREMENT SYSTEM

MicroStep-MIS aviation weather systems are designed to interface various types of sensors and data loggers. In-house development and production of hardware components as well as long lasting relationships with our suppliers allow us to deliver tailored solutions to our clients.

Top class among barometers

Digital Barometer MSB780 is designed for use in professional meteorological and aviation applications that require reliable and highly accurate measurement, fast dynamic response and advanced long-term stability. The barometer is built to withstand the most challenging environmental conditions, which are often faced in various environmental monitoring applications.

It is a low power consumption microprocessor controlled sensor suitable also for solar and battery powered applications. The sensor is operable in temperature range from -50 °C to +80 °C. The excitation range is from 5 to 35 V DC. This robust product is made of durable hardware components enclosed in heavy-duty metal IP 66 enclosure. It comes factory calibrated with a manufacturer calibration certificate.

Universal meteorological display

MD14 is a universal display for professional meteorology use designed for airports and industry as well as for meteorological stations as a lightweight replacement of the observer's screen or redundant backup to it.

The LCD display MD14 presents real time meteorological data as well as data calculated according to WMO and ICAO standards and recommendations. It supports configuration of up to 5 information tabs – typically used for 4 runways and a meteorological garden. MD14 comes preconfigured to one of the standard configurations; however, additional configurations can be ordered as per client's requirements.



Meteorological mast for wind measurement | installed in Jakarta as a part of IMS4 Low Level Windshear Alert System

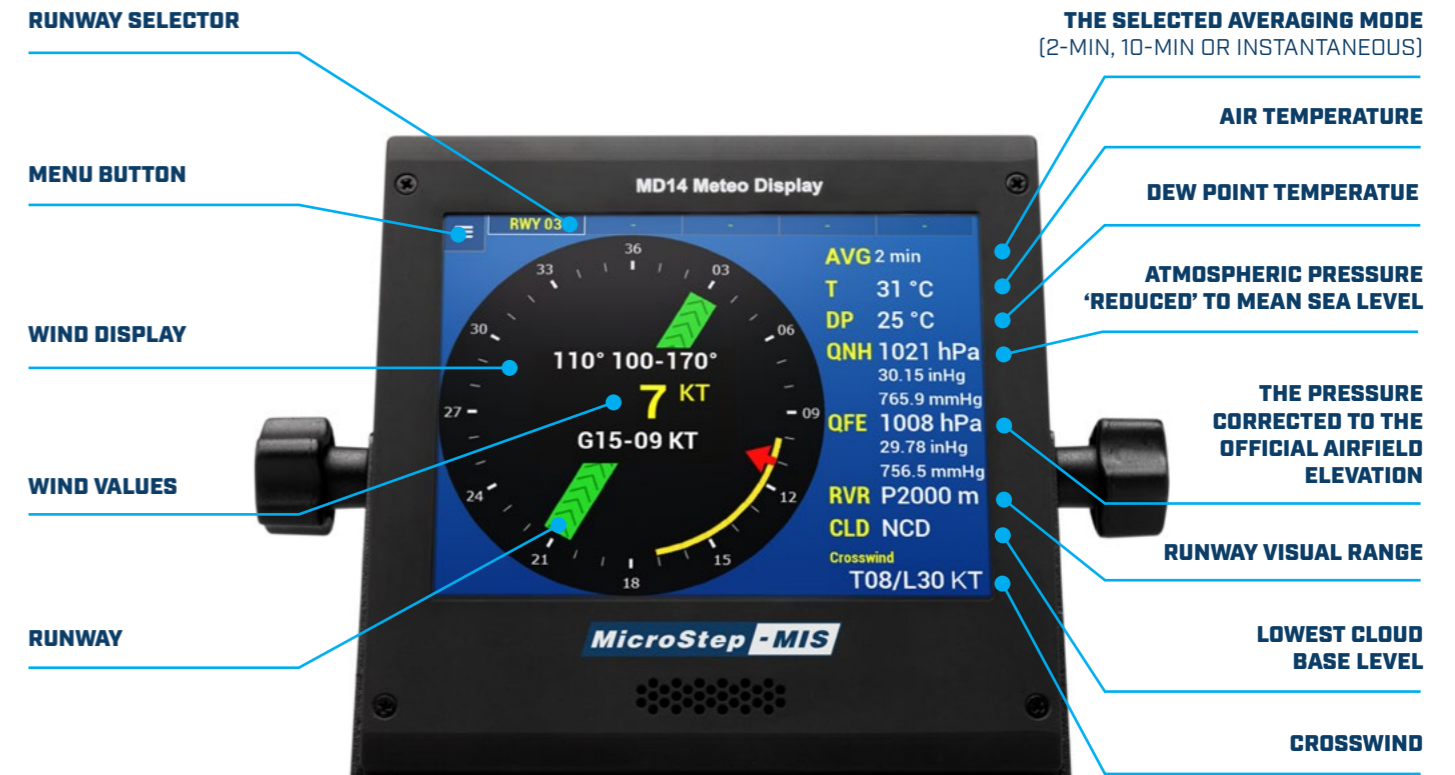

Universal Meteorological Display MD14 | The most complete configuration of aviation display for ATC TWR

IMS4 AUTOMATED WEATHER OBSERVATION SYSTEM

IMS4 Automated Weather Observation System is an airport weather observation system for regional, national and international airports. The IMS4 AWOS measures, processes, stores, presents and communicates all meteorological data at the airport.

The system integrates and provides weather data to observers, air traffic controllers, pilots and other users in form of real-time screens, graphs, WMO codes, alarms and voice reports. It interfaces upper air systems, Low Level Windshear Alert System and radars. The IMS4 AWOS conforms to all ICAO and WMO recommendations

regarding the measurements and reporting. It calculates various derived meteorological data such as QNH, QFE and Runway Visual Range, generates alarms, METAR, SPECI, SYNOP reports as well as national codes if required.

The system can interface numerous types of data loggers and sensors. It is designed to measure, calculate and process different meteorological quantities such as temperature (dry, surface, soil, soil under vegetation), wind speed and direction, pressure (station, QNH, QFE, QFF), relative humidity, precipitation (indicator and amount), runway surface temperature, freezing temperature for

different deicing materials, runway condition (dry / damp / wet / ice, etc.), visibility and RVR, cloud height, sunshine duration, solar and gamma radiation, evaporation, O3 concentration and it is open for adjustments and addition of any other quantities if needed.

The Central System is used as a central node for all communication networks and interconnects field sensors, displays and individual stations installed on the airport, thus enabling to backup these networks. The Central System makes all preprocessed data available to IMS4 Workstations and remote displays, thick or thin clients.

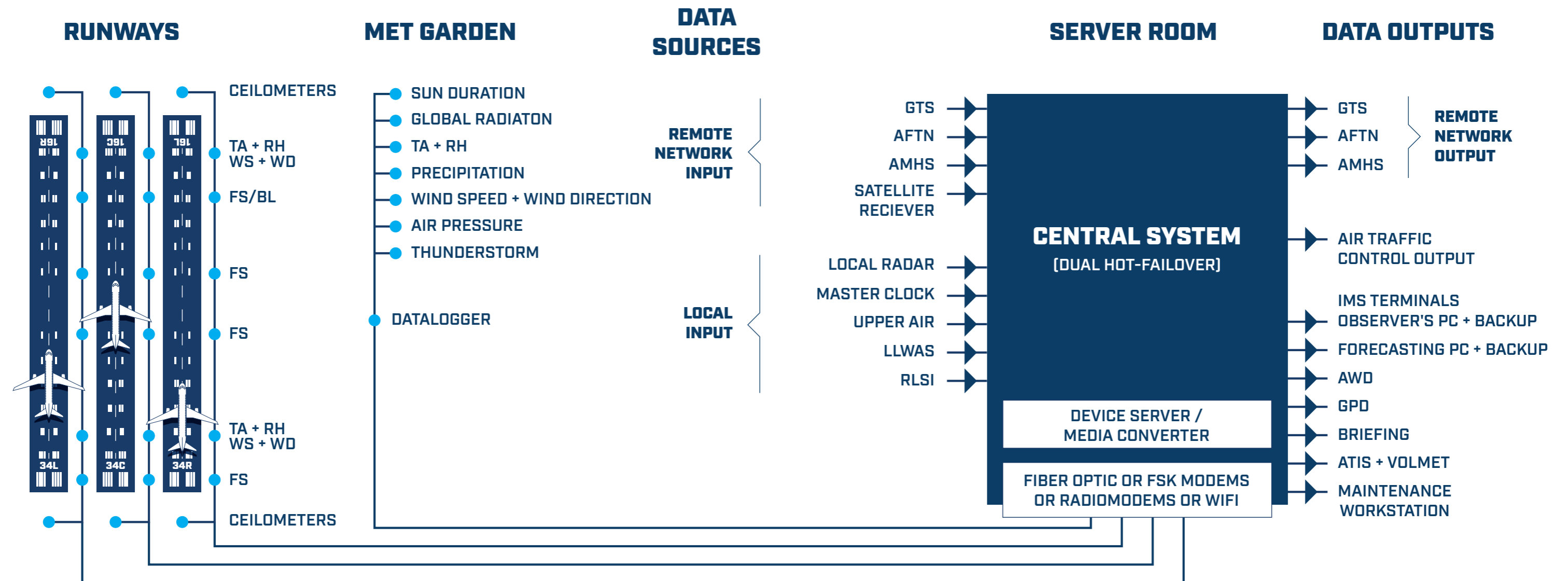
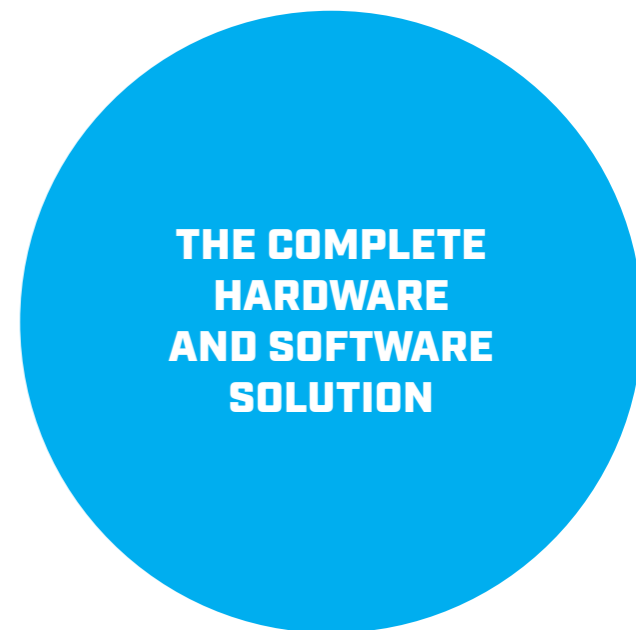

IMS4 AWOS scheme example for CAT II or CAT III airport



MicroStep-MIS' IMS4 AWOS has been installed at Decusse International Airport of East Timor

FROM SMALL REGIONAL AIRPORTS OR HELIPORTS SCALABLE UP TO ICAO CAT III MULTIRUNWAY OR MULTI-AIRPORT SYSTEMS



12 airports of Chinese Yunan Airport Group integrated into virtual multi-runway Automated Weather Observation System

The configuration and structure of a respective AWOS system depends on size and category of the individual airport. The modular architecture allows expansion from single Aviation Weather Display with basic set of sensors up to comprehensive system for multirunway airport connected to GTS and AFTN networks including a dual hot fail-over Central System, several Observer's Workstations, displays, terminals, briefings and ATIS / VOLMET services.

The well-developed upgrade programs allow our systems to follow technology progress and adapt to airport expansion and changes in regulations during its

lifetime. The IMS4 application software is capable to build the virtual multirunway Automated Weather Observation System collecting real-time raw or processed AWOS data from several regional airports and presenting them to the operators in the form of the virtual multirunway AWOS system with multiple runways.

Within the same airport, or on the other continent, IMS4 AWOS provides users with the powerful and efficient web interface. All the user needs in order to view the AWOS data is a standard web browser and Internet connection.



Example of multi-runway aviation weather display designed and customized according to customer's requirements. Parameter tendencies are marked by colors - deterioration is marked by red and improvement by green color.

IMS4 METREPORTER

IMS4 MetReporter is built on a modular IMS4 AWDS platform and it is an autonomous, easy-to-deploy and maintain fully automated weather observation system for general aviation, non-ICAO airports and heliports.

The system consists of:

- Embedded VHF Automated Terminal Information Service
- Embedded Automated Weather Observation Service

- Remote telemetry and control from local workstation over WiFi or GPRS VPN
- Optional computer based IMS4 Aviation Weather Display or full featured IMS4 Observer Workstation
- Optional data reporting to the upper system for flight planning (i.e. via cloud computing provider)
- Meets or exceeds applicable ICAO, WMO, EASA, CAAC regulations and recommendations

METREPORTER WEATHER STATION

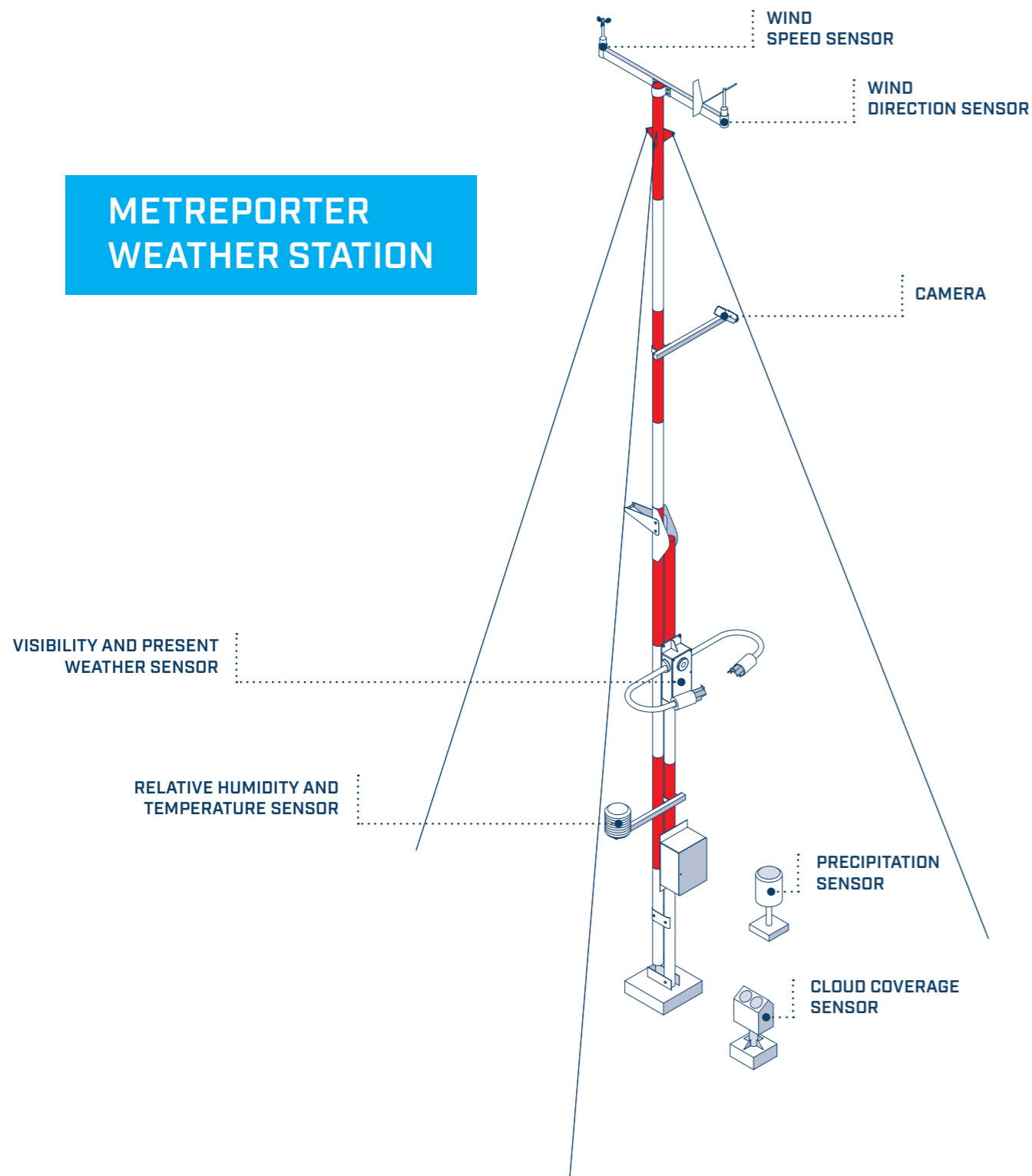

HELIDECK WEATHER STATION

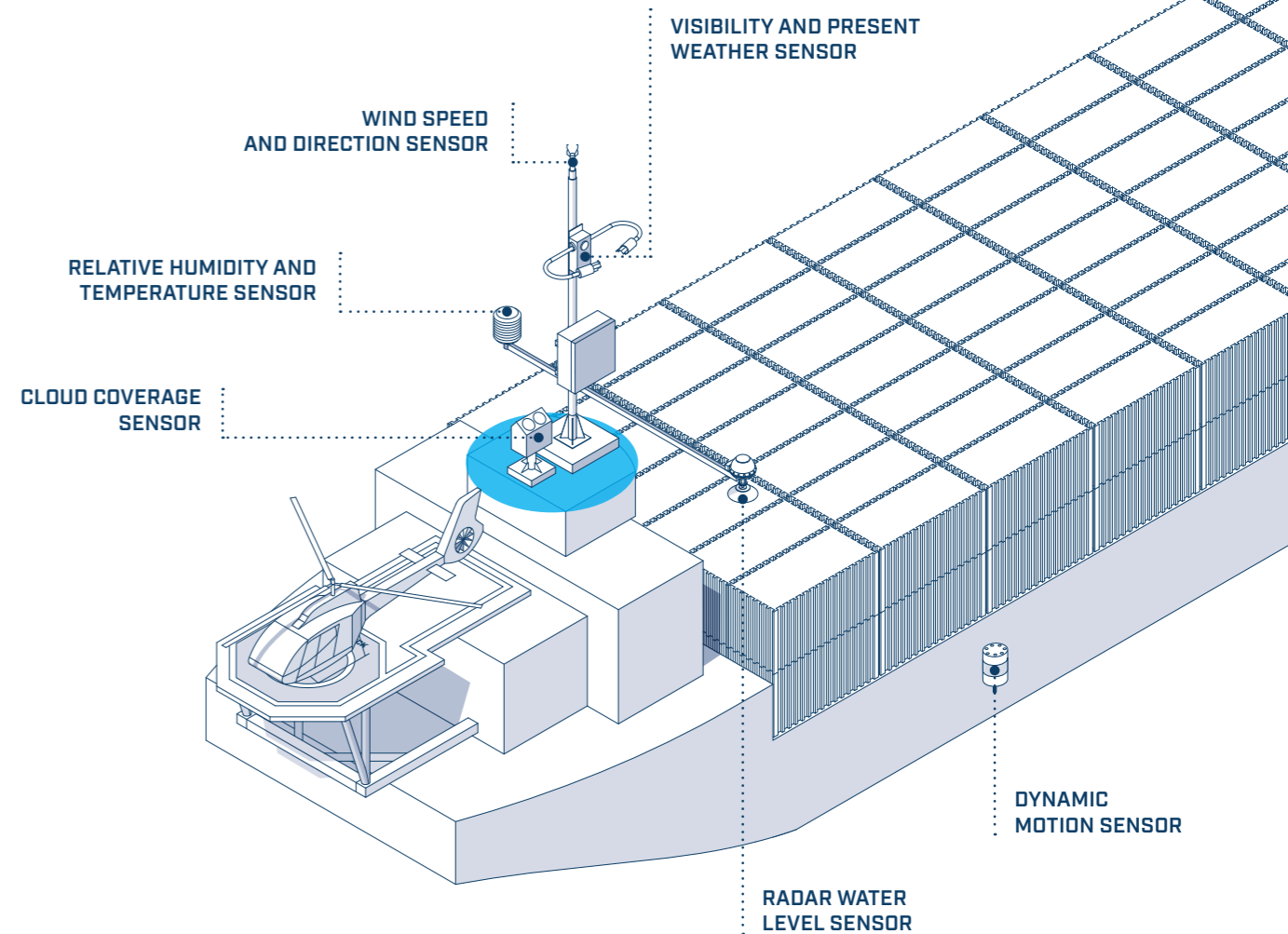

IMS4 HELIDECK

IMS4 Helideck Monitoring System is optimized to provide real-time weather conditions and monitoring of the helideck motion, thus ensuring the flight and passenger safety.

The monitored weather parameters include wind speed and direction, air and sea temperature, relative humidity,

barometric pressure, visibility and present weather, cloud height and wave height. In addition, the IMS4 Helideck monitors the helideck's heave, heave velocity, roll, pitch and inclination in real-time. The automatically generated helideck reports can be disseminated through various communication channels or optionally broadcast to pilots via VHF transceiver.

IMS4 LOW LEVEL WIND SHEAR ALERT SYSTEM

IMS4 LLWAS is the top-quality, automatic and reliable product considerably approaching technology to mitigate the riskiness of crucial flight phases of take-off and landing. The system is used by controllers to warn pilots of existing or impending windshear conditions.

Network of wind stations installed and situated near and along the airport runways measures average surface wind speed and direction. The system collects the measurements, performs the validations and recalculations, runs the algorithm to detect wind shear, generates the alerts and distributes the data and alerts to displays and 3rd party systems. Selection of proper sites and optimization of the algorithm are crucial for the site surveying teams.

System integration with IMS4 AWOS system is available and possibly bringing even more comprehensive, relevant, and highly useful data to the airport teams allowing them to significantly decrease the risk of a sudden disaster.



Soekarno-Hatta International Airport, Jakarta | MicroStep-MIS IMS4 LLWAS assists the operations at 20th businest airport worldwide, serving more than 63 million passengers annually (2019).

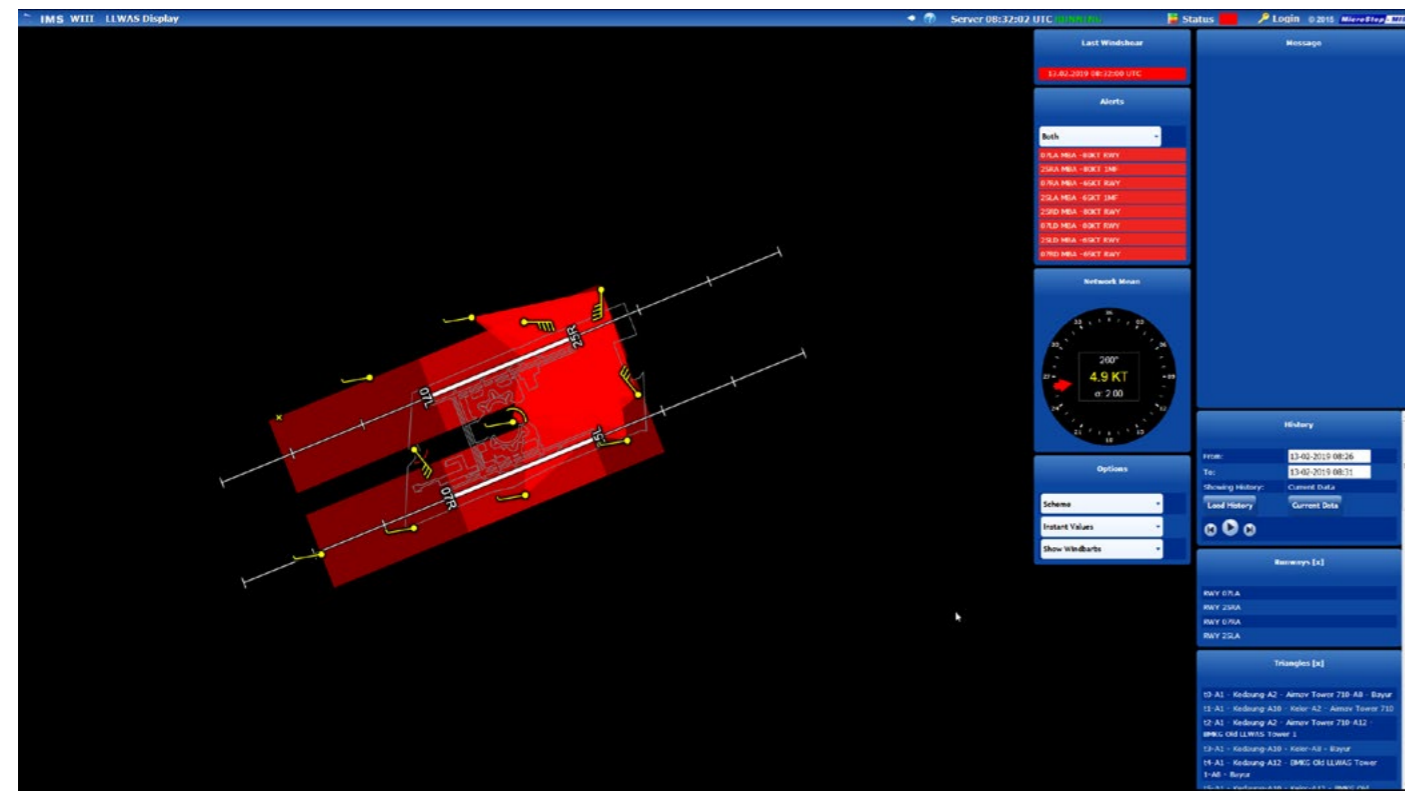

LLWAS Expert Display | It contains schematic view of runways, wind shear alert system measuring sites in the surroundings and wind shear alerts. There are also computing triangles and detail messages that are inter-results of computing of wind shear alert system. It is intended for LLWAS experts to inspect the situation.

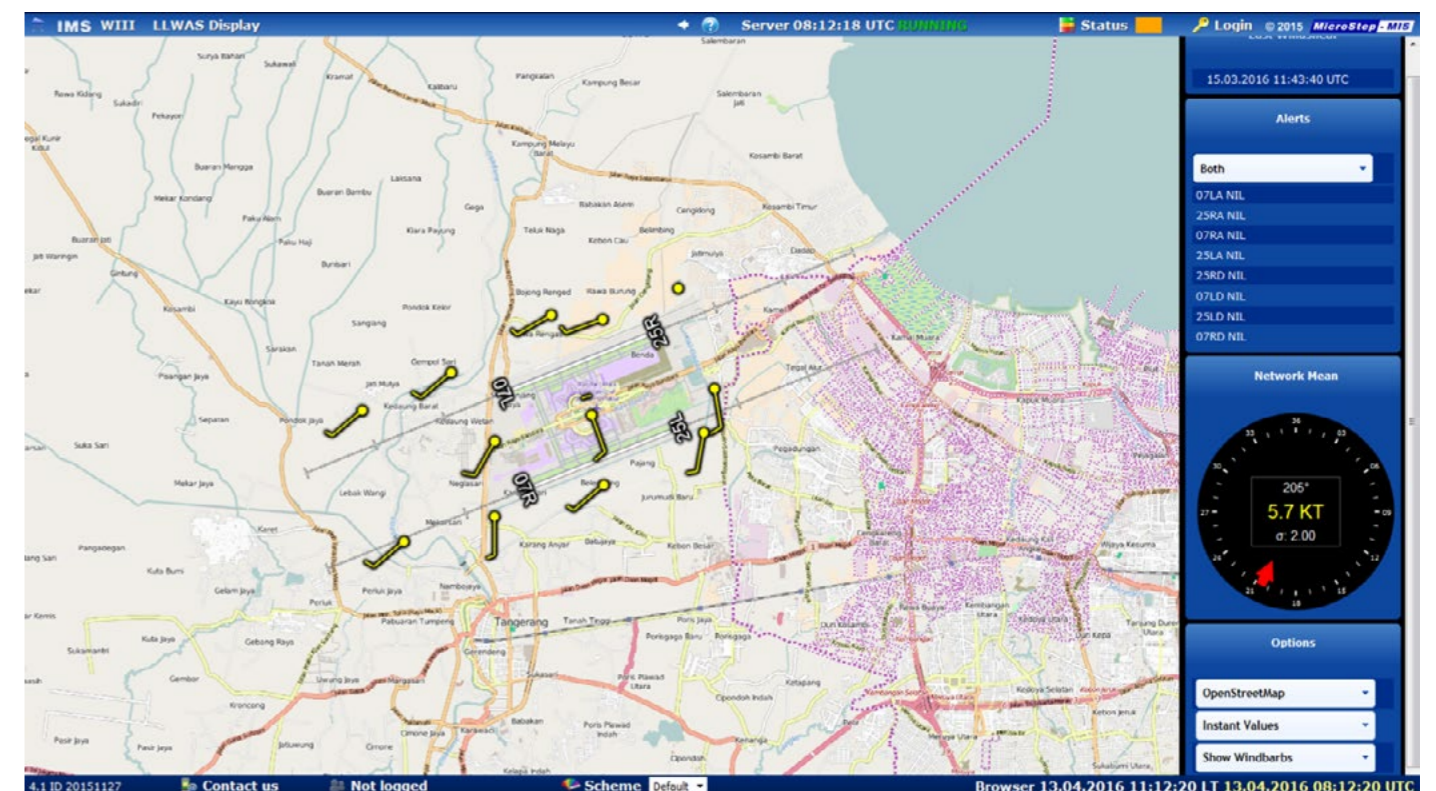

IMS4 LLWAS Total Screen | Airport visualization - map, actual warnings, wind data (digits or wind barbs), active alerts marked on the map by red color.

LIDAR FOR DETECTION OF LOW LEVEL WIND SHEAR

Detection of low level wind shear and timely automated warnings on it play a key role in the aviation safety, mostly in the phase of landing or take-off. Rapid advancement of new technologies based on lidars and / or small weather radars and their penetration into operational practice worldwide result in the fact that the detection of low level wind shear is being transformed into an integration and evaluation of multi-platform observations.

Besides the traditional technology of low level wind shear detection (based on synchronized wind observation by anemometers) MicroStep-MIS upgrades the alerting system by having a lidar-based technology integrated.

Within the research project A Novel Method for Low-level Wind Shear Alert Calculation from Data Measured by LIDAR (2016 – 2020) and with a financial support from



the Slovak Research and Development Agency, MicroStep-MIS purchased a lidar and installed it at Bratislava airport.

The target destination, M. R. Štefánik Airport in Bratislava, had been selected mostly on the basis of being the largest and the busiest one among the airports in Slovakia, and as well due to the orography and the climatological settings of the target area forming adequate circumstances for a (frequent) birth of hazardous meteorological phenomena such as wind shear.

The aim of the research project is to collect and analyze large number of synoptic situations with wind shear, and to develop our own, automatic, lidar-based low level wind shear alert system.

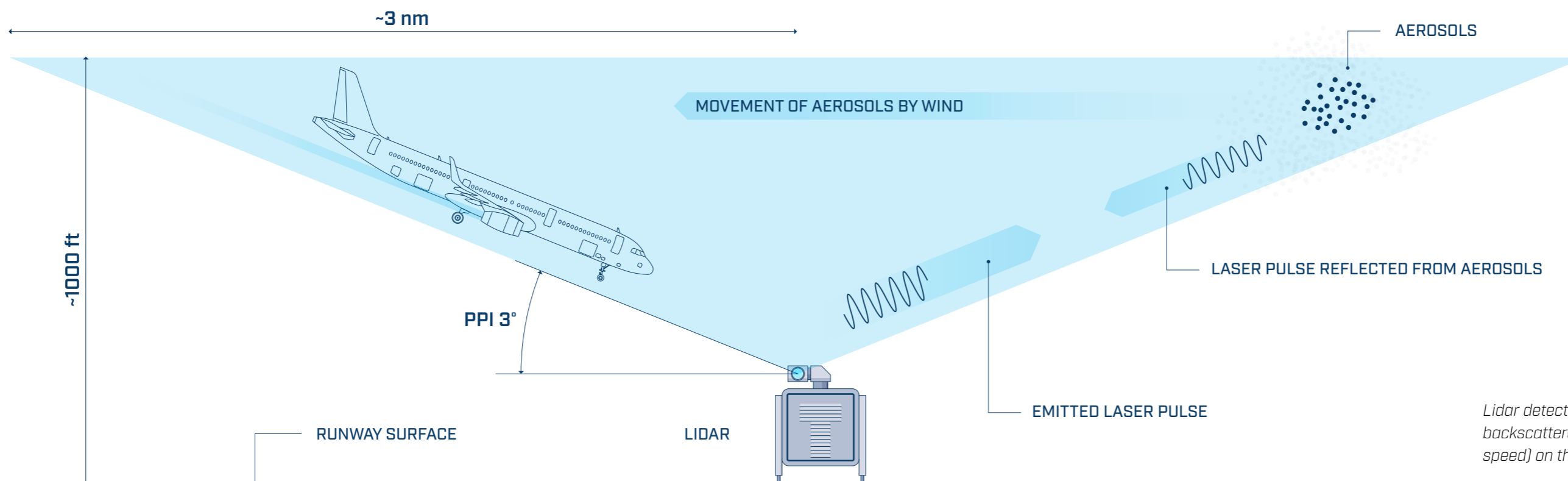

Lidar detects the frequency change of the backscattered pulse (hence, the radial wind speed) on the basis of the Doppler effect

IMS4 AIRPORT RUNWAY WEATHER INFORMATION SYSTEM

Using the real-time collected measurements from the field sensors as well as the data from the integrated model, the IMS4 ARWIS provides the airport authorities with the essential runway surface condition data. Generated early warnings contribute to air traffic safety and assist the maintenance service with planning the runway maintenance activities.

The system interfaces numerous types of sensors and data loggers. The active / passive intrusive runway surface

and subsurface sensors or non-intrusive optical sensors provide runway and subsurface temperature, freezing point, water film thickness and runway condition (dry, damp, wet, snow, ice, etc.).

The optional Automatic Weather Stations measure atmospheric pressure, wind speed and direction, temperature / dew point, present weather, precipitation, snow depth and the system is open for measurement and processing of the other quantities.



Airport Runway Condition Display

**READY FOR
NEW GLOBAL
REPORTING
FORMAT**

RECENT IMPROVEMENTS

Being involved in the SESAR research projects, MicroStep-MIS has significantly improved and upgraded the IMS4 ARWIS within the Solution PJ03b-06 - Safety support tools for runway excursions.

The system is now fully compliant with the new ICAO regulation introducing new Global Reporting Format (Annex 14 and Doc 9981), all applicable from November 2021.



AQUAPLANING ASSESSMENT AND NOWCASTING

The newly featured IMS4 ARWIS has recently been deployed and integrated at Malta Luqa Airport. Integration of aquaplaning into the system, compliant with current ICAO regulations (implementation of Runway Condition Report) and additional integration with radar-based nowcasting enable the system to provide and generate more precise RWY condition assessment.

Moreover, implementation of prediction model is beneficial in order to access better quality of consolidated data necessary for winter runway maintenance. Graphical user interface can be customized according to the particular requirements of the customer.



Aquaplaning / precipitation display shortly after the storm

Laser precipitation monitor

Temperature and relative humidity sensor

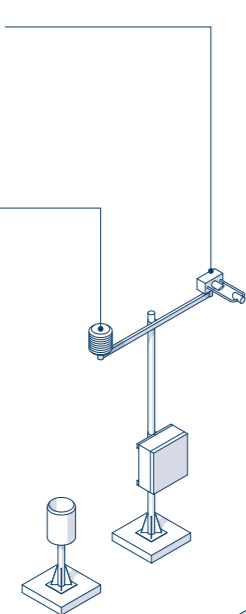

Runway surface measurement sensor

Precipitation sensor

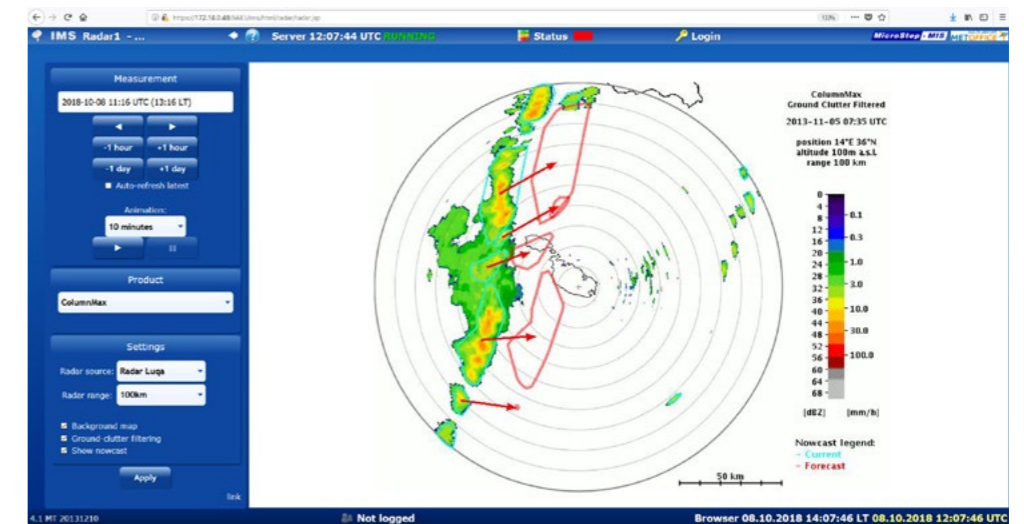
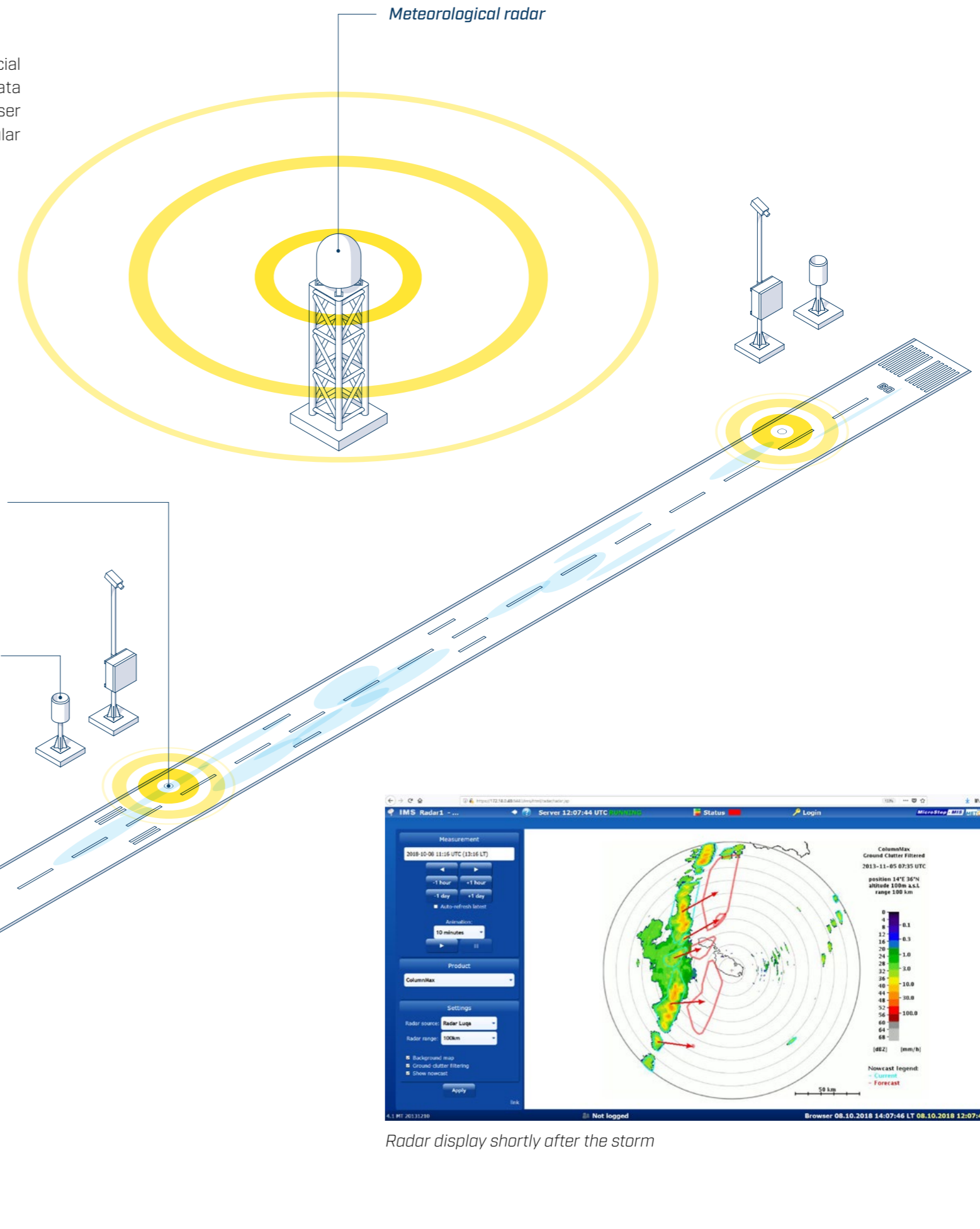

Radar display shortly after the storm

IMS4 ATIS / VOLMET

The IMS4 ATIS / VOLMET system benefiting from more than 27 years of MicroStep-MIS' experience in the field of meteorological service for civil aviation provides arrival, departure or combined ATIS and VOLMET broadcast and datalink services for airports from regional up to major international airports.

The system can be installed as a standalone or as an integrated part of the company's IMS4 AWOS with permanent access to the AWOS data.

The open architecture allows easy expansion from the basic single channel system (combined departure and arrival ATIS service) up to the multi-channel ATIS / VOLMET system (separate broadcasting channels for airport with multiple runways, multichannel service for group of airports etc.).

Variety of system options include but are not limited to:

- Multiple channels and / or multiple languages
- Dual hot-failover configuration and / or redundant transmitter equipment as a guaranty of the highest possible system reliability
- Remote operator and control positions for convenient authorized access to the system
- Telephone interface for the preview of current broadcasted reports

The semi automated or manual mode can be also configured for specific channels, if required, with visual and audible warnings announcing new data availability and new report compilation.

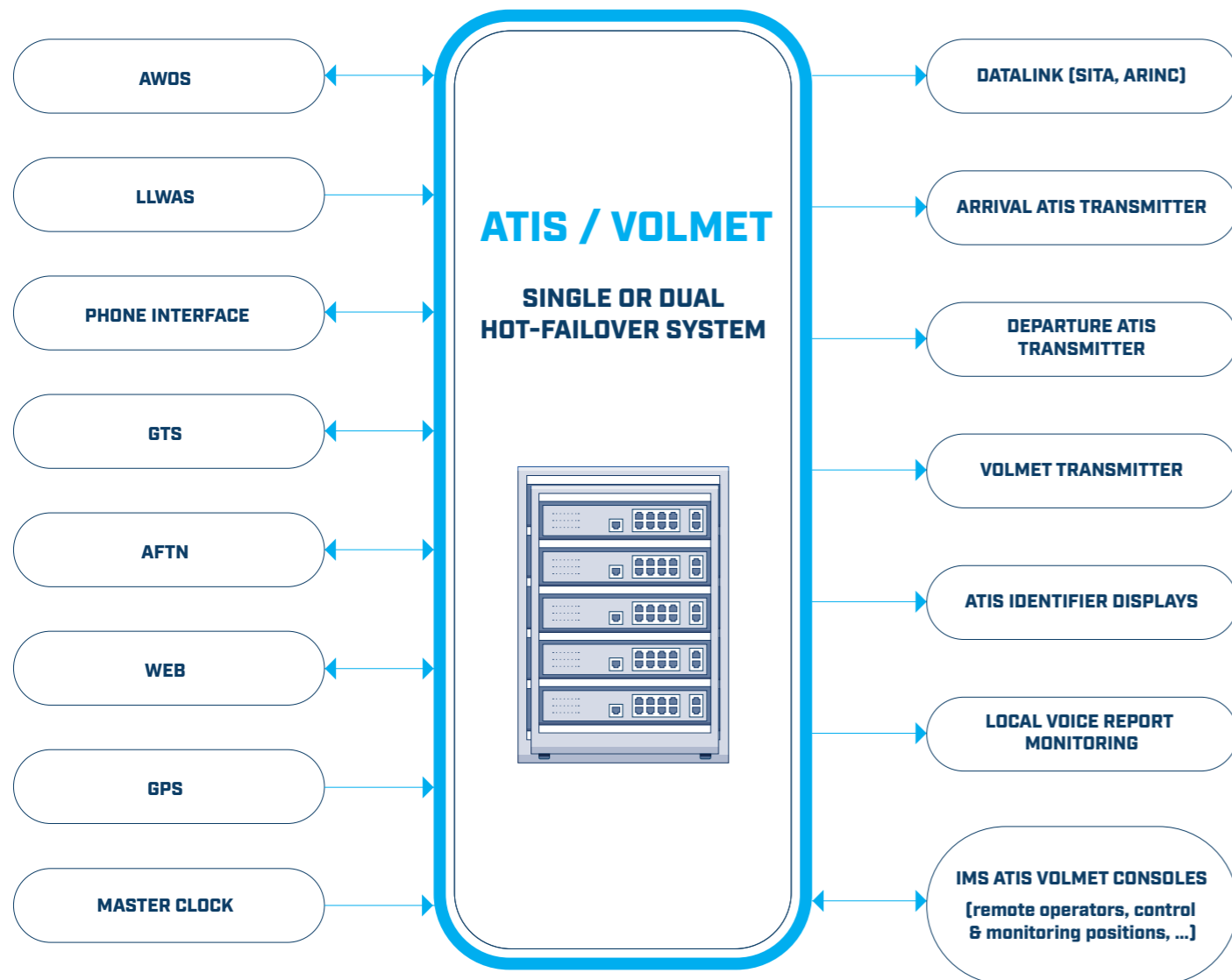

IMS4 PILOT BRIEFING

IMS4 Pilot Briefing supplies meteorological information to aviation users in order to ensure the safety and regularity of air navigation.

The workstation facilitates collecting and printing of flight documentation for pilots based on the local meteorological data and messages received from GTS or AFTN networks. The system integrates automatic handling of data validation. The users can easily collect and print all necessary flight

documentation containing the local conditions, conditions at the destination and along the flight route. A single definition of the flight route into the system is sufficient for the system to master this task in a few seconds time.

The system also warns users about all received meteorological or operational warnings like volcanic ash or tropical cyclone advisories as well as other warnings and administrative messages.

IMS4 RUNWAY VISUAL RANGE SYSTEM

The IMS4 Runway Visual Range System performs the automated runway visual range assessment and reporting for the airports.

The typical set of IMS4 RVR field measurement system consists of forward scatter meters, background luminance sensors as well as interfaces to runway lights systems.

The data processing software enables any standard or non standard combination of sensor positions along the runways, hot backup of the sensor values and manual data entry. For each sensor type, the evaluation and visualization of the sensor status as well as remote maintenance are provided.

Besides collection of the visibility data from the field and calculation of runway visual range, the server distributes the data and alerts to displays as well as third parties.

Customizable displays report touchdown, midpoint and rollout RVR and / or MDR current values or trends, in accordance both with the ICAO regulations as well as respective ATC authority requirements. The built-in aviation web server provides the local airport controllers and remote users with the powerful and efficient web interface.

Forward Scatter Meter | VPF 700 series supplied by Biral



FOG MONITORING AND FORECASTING

Measuring stations are of a great importance. They are used in machine learning of data mining models, provide real-time data for operative modeling and instant data for decision-making.

In addition to the airport meteorological station, one or more local stations covering the area around airport can supplement the system in order to serve other additional purposes such as road service.

All the data are available frequently, every 2 minutes, excluding the camera data. Camera images provide additional visual information for users of sensor data. They have proven to be useful for the verification of visibility conditions.

The fog prediction is a product based on IMS4 Model Suite models and tools as follows:

- 3D regional weather prediction model
- 1D fog prediction model
- Data mining models
- Satellite images



IMS4 AIRPORT LIGHTNING ALERT SYSTEM



IMS4 Airport Lightning Alert System addresses the top severe weather threat of the airport operations. The system can operate independently or integrated within IMS4 Automated Weather Observation System.

The IMS4 Airport Lightning Alert System represents the combination of the standalone lightning detector and the

lightning detection network data, thus benefiting from the both technologies. The system provides:

- detection of electrostatic field and / or charged precipitation providing an early warning even before the overhead clouds develop,
- detection of in-cloud and cloud-to-ground lightnings, storm cells identification and nowcasting.

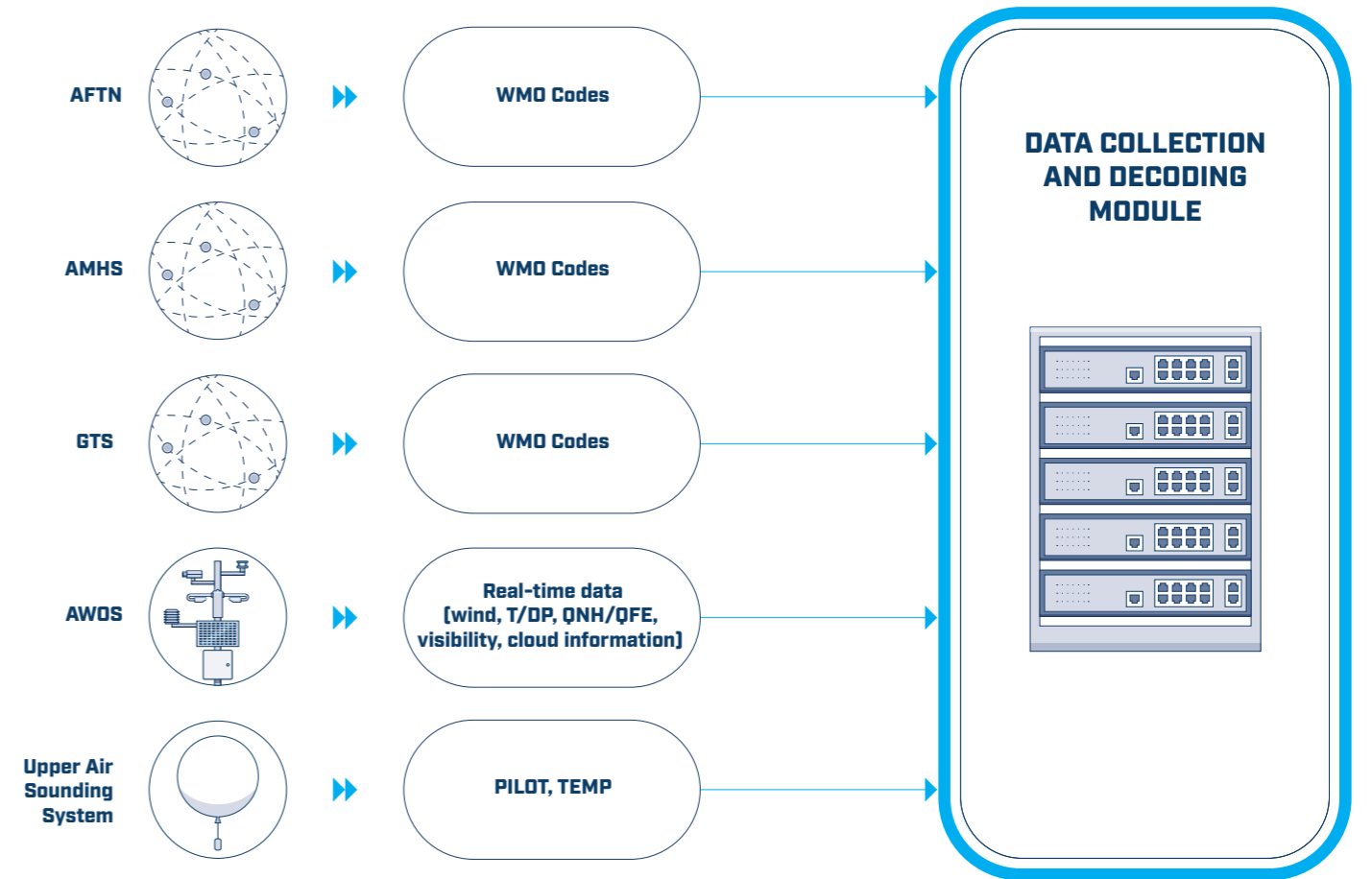
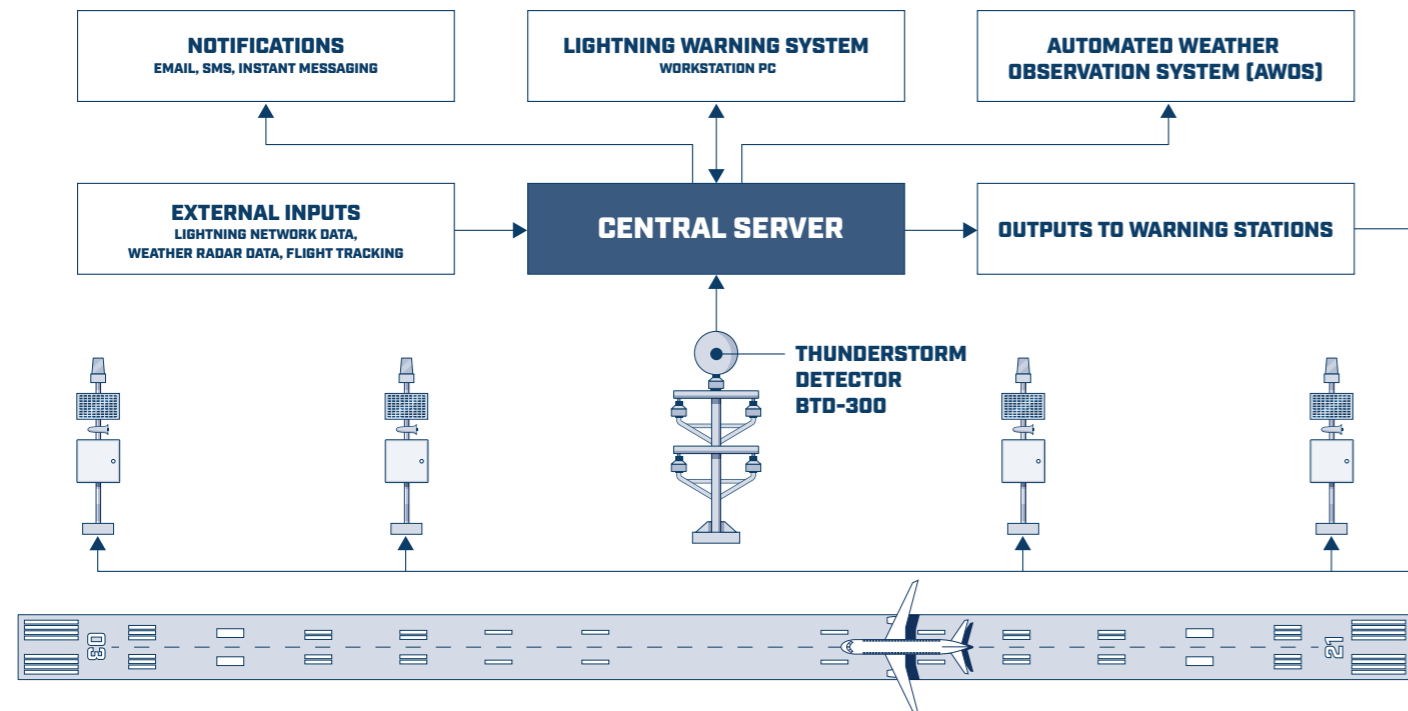

AERONAUTICAL CLIMATOLOGICAL DATABASE

Climatological Database (CLDB) is a database system addressing the needs of the metstore the high-volume long-term meteorological, climatological and environmental data.

The CLDB stores all collected data in one unified structure, thus avoiding data inconsistencies and discrepancies and enabling standard comfortable data access for all users and other software systems. No additional storage and no different and confusing data formats are needed. Within the Climatological Database the mentioned structure is based on SQL Database Server and the standard data access is based on SQL language.

CLDB is based on WMO recommended practices for climatological data processing (WMO Guide No.100) and it follows the WMO suggestion of a RDBMS (Relation Database Management System) application with wide use

in climatology (World Climate Program efforts concerning new Climate Data Management Systems - CDMSS).

The Aeronautical Climatological Database (Aero CLDB) is a CLDB variant fully compliant with the ICAO / WMO requirements related to the preparation of the Aerodrome Climatological Summaries.

In addition, the database is an ideal tool for the advanced statistical data post processing and with the incorporated sophisticated quality control modules it is ready to serve for the evaluation of the quality of service indicators for the particular MET service provider.

Having been integrated into the IMS4 Aviation Weather Decision Support System, the Aero CLDB serves as the data source for the data mining models (fog detection and forecasting, cloud coverage, etc.).

IMS4 AVIATION WEATHER DECISION SUPPORT SYSTEM

IMS4 AWDSS integrates all existing weather information in order to generate a collaborative, net-centric and combined picture incorporating seamlessly all aviation relevant weather sources.

In order to provide the air traffic controllers and meteorologists with the accurate operational information the IMS4 AWDSS processes the real-time data from various sources: local AWOS, ARWIS and LLWAS systems, weather radars, surface observations from the WMO / ICAO exchange networks, meteorological satellites, profilers, etc.

The collaborative, net-centric and combined picture incorporating seamlessly all aviation relevant weather sources, enables various users at the airport to have access to all essential information needed for tactical decision support during the flight phases: take off, departure, metering / descent, final approach and landing.

Having employed the state-of-the-art algorithms and forecast models, the system evaluates the general situation, area, airport specific and runway oriented alerts, using the color status signalization to visualize the hazards, if any.

The current as well as anticipated operational situation may be characterized by the alerts of the hazardous phenomena, current / anticipated airport / runway operational category, NATO color code or in the other way compliant with the operational procedures of the particular airport.

RUNWAY SELECTION

ATCO OR CONCERNED STAKEHOLDER SELECTION

MAIN TABLE WITH EVALUATED FORECAST AGAINST AIRPORT SPECIFIC CONFIGURABLE THRESHOLDS

FORECAST TIME HORIZON SELECTION



ATC Forecast Screen | The screen layout can be customized as per particular ATC / CAA requirements. Different levels of MET-based alerts are recognized according to intensity / impact on airport operations.

SESAR | FROM RESEARCH TO INNOVATIONS

As the technological pillar of Europe's ambitious Single European Sky initiative, SESAR is the mechanism which coordinates and concentrates all EU research and development activities with the objective to develop the new generation of Air Traffic Management.

Today, SESAR unites around 3 000 experts in Europe and beyond. MicroStep-MIS brings the expertise and experience as a linked third party to Polish ANS provider PANSA in fields of scientific research and concept developments. PANSA is a member of B4 Consortium representing medium and small-sized European Air Navigation Service Providers from Poland, Czech Republic, Slovak Republic, and Lithuania.

MicroStep-MIS participated in the program SESAR2020 Wave 1 on four industrial research projects. In particular we focused on providing safety support tools for runway excursions, enhanced collaborative airport performance management, advanced automated aviation meteorology

systems, and tools for managing and sharing trajectory data.

At the end of 2019 MicroStep-MIS together with PANSA and WARSAW University launched the preparation for a second wave of this prestigious program. The Wave2 projects build on the completed first phase of the program and their aim is further enhancement and increase of maturity level of the ATM Solutions. MicroStep-MIS is participating on two projects.

1 Solution PJ.02-W2-25 Safety support tools for avoiding runway excursions

Runway excursions represent one of the most frequent accident category for worldwide accidents. Safety support tools for avoiding runway excursions aim at

detecting, preventing, and alerting risks of runway excursions by synchronizing air-ground information exchange about runway surface condition.

The Solution Safety support tools for avoiding runway excursions is part of the project PJ02-W2 Airport airside and runway throughput. The objective of this SESAR Solution is the mitigation of the runway excursion risk at any airport operational environment, based in particular on the ICAO Global Reporting Format relating to runway surface conditions.

MicroStep-MIS intends to contribute by providing its knowledge and expertise in aviation meteorology through the work on technical and partially operational aspects of the Solution. MicroStep-MIS continues in the work done in SESAR Wave 1 project PJ03b-06 on the development of the ground system for estimation, reporting, and dissemination of

current and predicted runway conditions (model integrating available input data, dedicated HMIs, RCR editor, etc.), compliant with GRF. We participate on an integrated shadow mode V3 validation exercise at Gdansk Airport led by PANSA with support of Airbus and Dassault (onboard systems) and the University of Warsaw supplemented by RTS of rare and non-nominal situation.

2 Solution PJ.04-W2-29 Digital Smart Airports

The need for European airports to become more operationally efficient is fundamental. This SESAR project will develop concepts, tools and procedures to increase the predictability and resilience of airport operations, improving the punctuality of flights in a safe and environmentally sustainable manner.

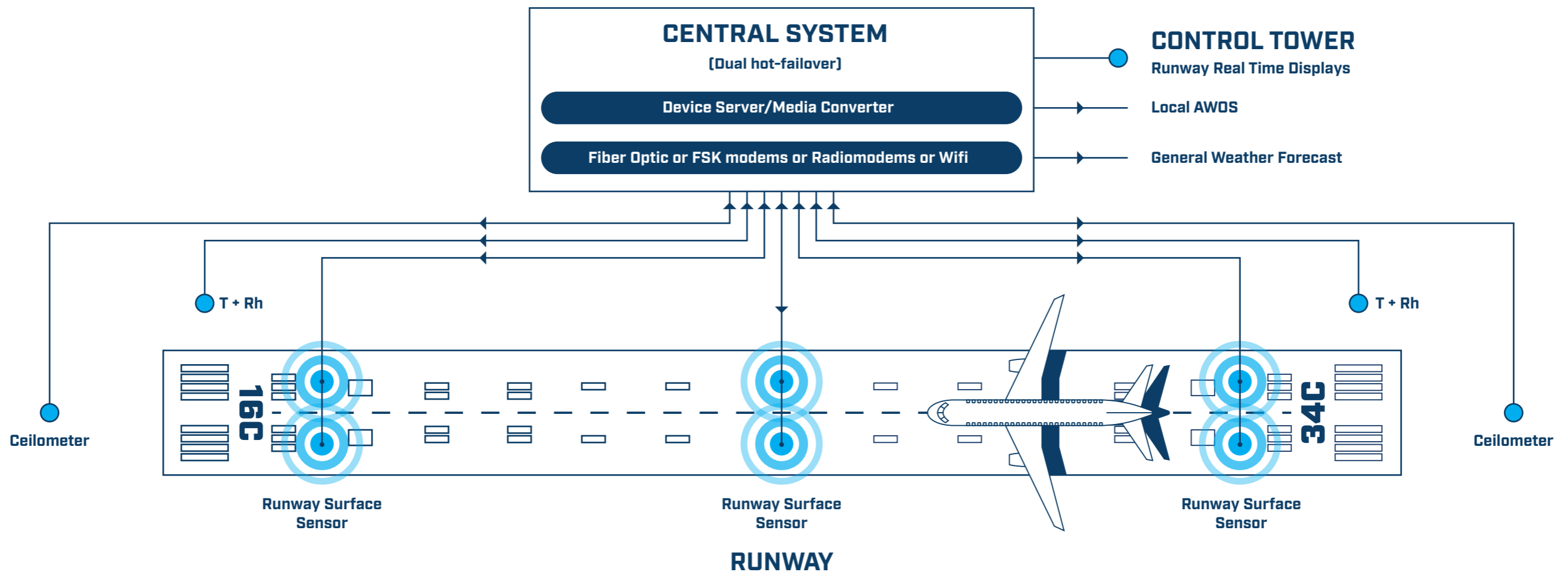

The Solution Digital smart airports is part of the project Pj04-W2 Total Airport Management. It consists of three parts (subsolutions):

- Airside/Landside performance management
- MET performance management
- ENV performance management

The subsolution MET performance management aim at Pro-active management of MET impacts on the AOP (Airport Operation Plan). Meteorological impacts on the AOP are pro-actively managed by decision support functionalities that can assess the impact of key meteorological conditions on airport performance and that can propose pre-defined solution scenarios.

MicroStep-MIS intends to contribute by providing its knowledge and expertise in aviation meteorology through the work on technical and partially operational aspects of the Solution. MicroStep-MIS continues in the work done in SESAR Wave 1 project Pj04-02 on development of the advanced aviation weather decision support system (AAWDSS) including the observation as well as forecasts of hazard weather phenomena for management of its impacts. We participate on RTS V3 validation exercise led by PANSAs with support of University of Warsaw and DLR (thunderstorm nowcasting). That includes also integration of AAWDSS with PANSAs Advanced Tower system (for prediction of TTOT, TSAT and taxi times).





180+

talented and dedicated
professionals working
together



380+

*aviation weather
systems*

CONTACT US

info@microstep-mis.com

www.microstep-mis.com

